



2024 SIJRA QUEEN/PRINCESS CONTEST for **2025 Season**

- **Friday, October 11th Optional Horsemanship Clinic at SIJRA Arena-7pm**
Application and entry fees for contest are due September 14th Rodeo
- **Saturday, October 12th Judging of Horsemanship portion of contest-8am at SIJRA Arena**
- **TBA - (Day of Awards Banquet) Judging of Speech & Interview portion of the contest at 2pm (Banquet Location)**

There are 3 age divisions: K-1-2 Princess; 3-4-5 Princess, 6-7-8 Queen. The kids will be competing in the age division that they will be in for the 2024 season (the grade that they are in for 2023/2024 school year. The contestants will be judged in three categories: **Horsemanship, Appearance, Personal Interview and Speech**. Each category is worth 1-25 points.

The Horsemanship portion will be judged at 8am, Saturday, October 12th prior to the start of the rodeo. This pattern WILL BE JUDGED as a horsemanship pattern. Please have your horse warmed up and ready to run your pattern at 8am! The judges love promptness!

The Interview, Speech & Appearance will be judged at 2 pm at the Awards Banquet before the SIJRA Awards Banquet (TBA). The speech topic will be announced at the October rodeo at the Horsemanship Contest. The new 2025 Princesses and Queen will be crowned at the SIJRA Awards Banquet. The same 2-3 judges that judge the horsemanship portion will return to judge the speech and interview portions, as well.

The 3 winners will each carry a flag during the Grand Entry of each of the SIJRA rodeos. In the event that our Queen or one of our Princesses cannot make a rodeo, this responsibility will be assumed by the Runner-up in that age division. The Queen and her Princesses' (families) will present awards day of each rodeo at the awards table. If they cannot fulfill their duties, they are expected to assign someone to assist. The winners will also present awards at the SIJRA Awards Banquet.

Good sportsmanship will be expected of these young ladies at all events. They are expected to uphold a high standard of kindness, compassion, caring and helpfulness inside and outside the arena. This includes other sporting events, school, and in everyday life. Duties may include sales, leadership for younger children, nightly event coordination, etc. The Board may impose sanctions if these standards are not met.

Please read the Queen/Princess Contest Section in the 2023 SIJRA By-Laws, Rules & Regulations for more details.

To compete, fill out the Queen/Princess Contest Application. **The Application, along with a \$15 entry fee (payable to SIJRA), must be turned in at the announcer's stand or by the end of the rodeo on September 14, 2023. NO EXCEPTIONS.**

GOOD LUCK!

Questions- contact: Gary Allen 502-905-7431



2024 SIJRA QUEEN/PRINCESS CONTEST APPLICATION

Name _____

Address _____

Phone _____ Phone _____

Age _____ Email _____

Grade (as of 1/1/2025) _____

****Due by September 14th with Entry fee of \$15 (payable to SIJRA)****

Check one of the following divisions: (Using grade as of 1/1/2025)

K-1-2 Princess

3-4-5 Princess

6-7-8 Queen

What grade are you in and what school do you attend?

Clubs, Hobbies, Accomplishments and Awards

Name & Age of horse you are using

Events you participate in at rodeo

I want to represent the SIJRA because

HORSEMANSHIP-This category is judged upon how well you handle your horse throughout a designated pattern and WILL BE JUDGED as a horsemanship pattern. Judges will look at your ability to sit the horse, hand & body position, delivery of cues and accuracy of pattern. (See attached pattern-each age category has its own pattern) Take time to practice the pattern at home! If you have any questions, feel free to ask! Don't feel like you have to be able to execute the pattern perfectly-just do your best!

Faults in this category include losing or touching your hat, losing your stirrups or reins, bucking, wrong leads, touching the saddle with hands, using both hands on reins or switching hands.

Dress wear for horsemanship is:

- Blue western jeans or pants
- Plain white shirt or blouse with a collar, long sleeves-with no fringe or sequins. Shirt must be tucked in.
- Hat or helmet, boots and belt are required
- Gloves and chaps are NOT permitted Tack for horsemanship contest
- Western style saddle
- Any type of bit or hackamore
- Tie-downs and protective boots are allowed
- Roping or split reins-although riding one-handed is preferred

PERSONAL INTERVIEW- Each contestant will be asked several general "impromptu" questions about herself during the interview. There will also be some questions about the rodeo, as well as some questions concerning their knowledge of the rules concerning the particular events that they participate in. The judges will score each contestant according to how well she presents herself, her composure and mannerisms while answering the questions. Watch your use of grammar and enunciation of speech. This is a great time for your personal character, sense of humor and personality to shine through! Have fun with the judges and relax!

SPEECH- The speech will consist of a self-written essay on the topic chosen by the current Queen. Princess speeches are to be one to two minutes in length. Queen speeches are to be two to three minutes in length. Use of your notes will be penalized but not disqualified. You will be judged on the following:

- Content
- Use of grammar and language
- Speaking ability
- Composure & delivery

2025 Topic-To be announced at Horsemanship Contest

APPEARANCE-Appearance will be judged during the Interview and Speech portion of the Contest.

The Personal Interview, Speech & Appearance will be judged at the awards banquet.

Attire for these three divisions is “full western dress” which includes:

- Long-sleeve, western shirt, blouse or jacket, or dress
- Skirt, pants or jeans
- Hat & Boots are required
- Belt is required for a “tucked in” shirt, but optional for a jacket that is worn on the outside of your pants or skirt or dress.

Clothes should be neat, clean and pressed. Hats clean and nicely- shaped. Boots should be cleaned and polished.

K-1-2 HORSEMANSHIP PATTERN

- Begin at cone A.
- Walk to cone B.
- At cone B, trot a circle to the right.
- Upon completion of the trot circle, pick up the left lead and lope a loop around to cone C.
- Stop and back 5-6 steps.

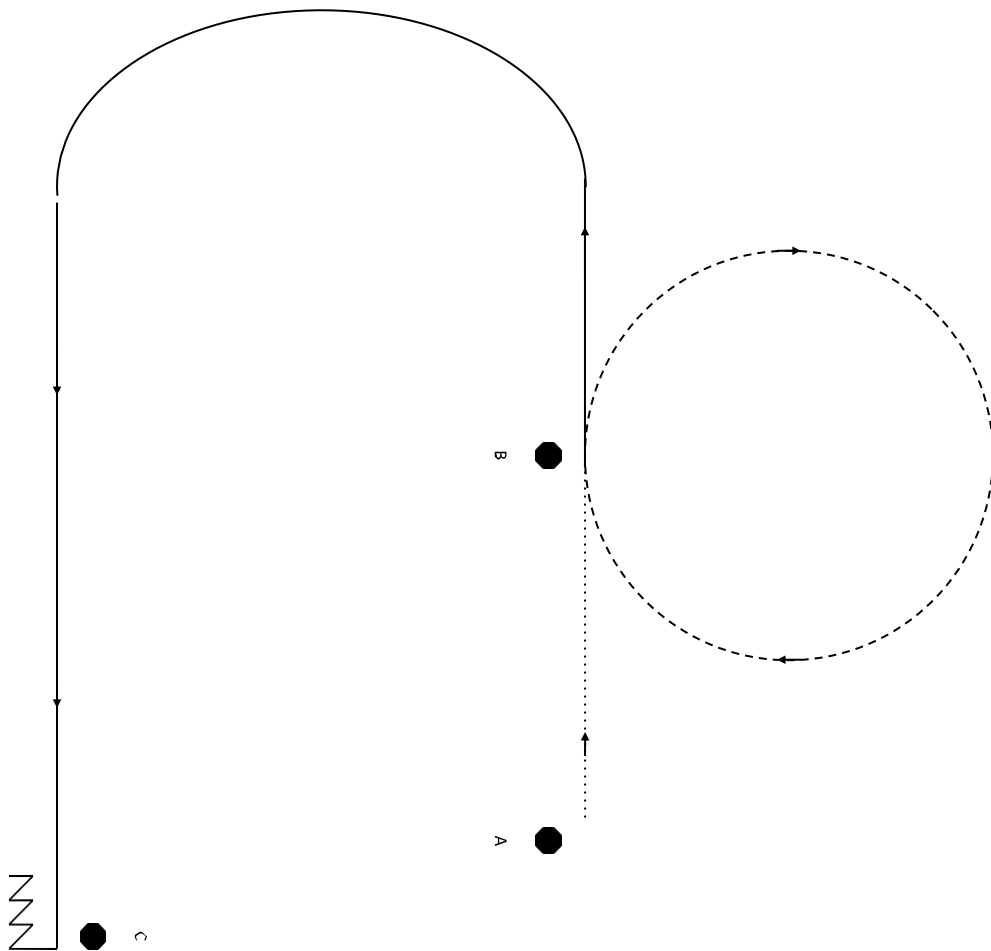

3-4-5 HORSEMANSHIP PATTERN

- Begin at Cone A.
- Trot to Cone B and trot a circle to the right.
- Upon completion of the trot circle, pick up your left lead and lope a circle to the left.
- Lope on and lope a loop around to cone C.
- Stop and back 5-6 steps.

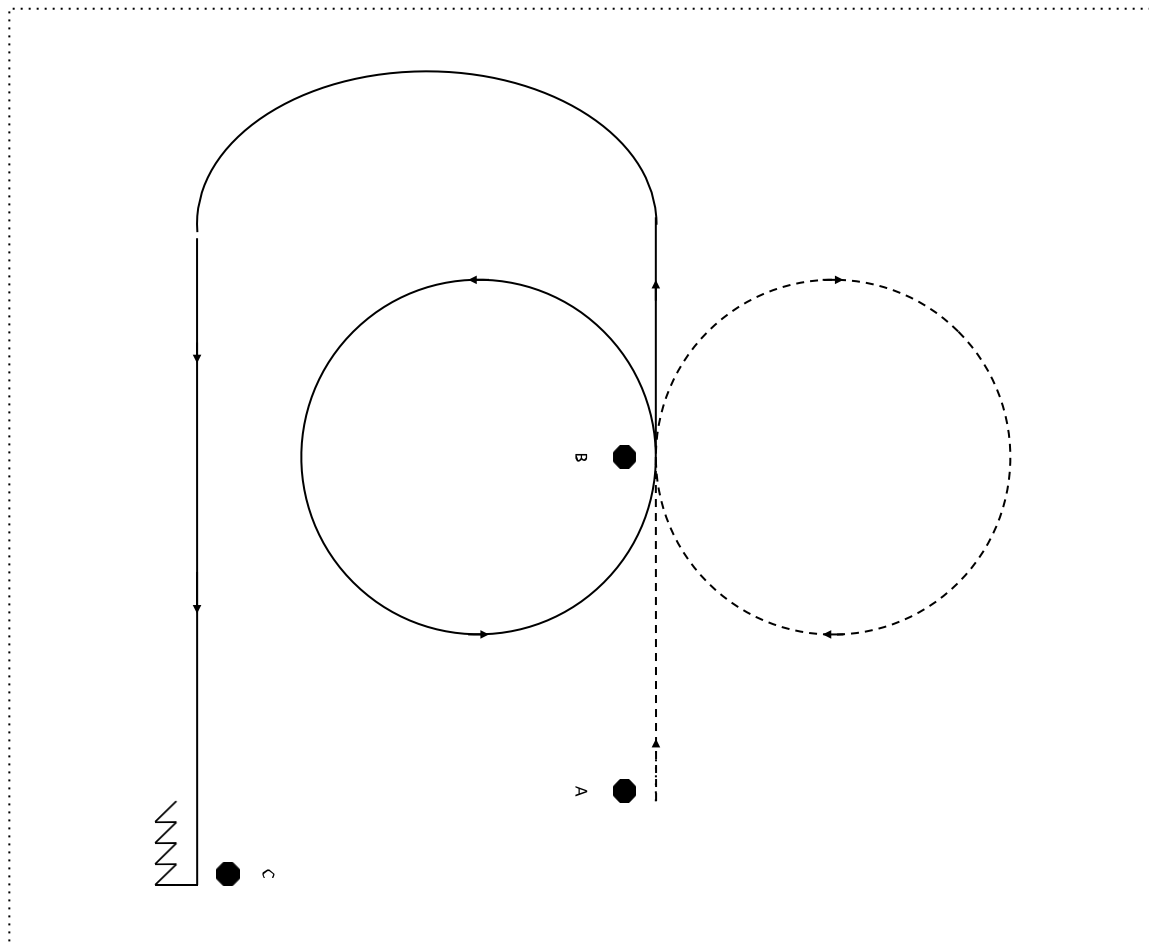

6-7-8 HORSEMANSHIP PATTERN

- Start on the right side of the arena and lope to the far end of the arena.
- Stop and rollback to the right. Continue to the other end of the arena.
- Stop and roll back to the left. Continue to the center of the arena.
- Lope a small slow circle to the left.
- Lope a larger, faster circle to the left.
- Change leads.
- Lope a small slow circle to the right.
- Lope a larger, faster circle to the right.
- Lope to cone B.
- Stop and Back 5-6 steps.
- Exit the arena at a trot.

